



EFD1000 and EFD500 Instructions for Continued Airworthiness

AIRCRAFT MAKE: _____

AIRCRAFT MODEL: _____

AIRCRAFT SERIAL NUMBER: _____

Modification of an aircraft under the EFD1000 AML Supplemental Type Certificate obligates the aircraft operator to include the maintenance information provided by this document in the operator's ICA, Aircraft Maintenance Manual and operator's Aircraft Scheduled Maintenance Program.

Aspen Document # 900-00012-001 Revision AD

ICA – RECORD OF REVISION

Revision	Description of Change	ECO
ICA Revision IR through Revision Q	See ECO record	See ECO record
R	Added Operator Security safeguards information	3262
S	Improved Security Safeguards information. Presented checklist suggestions in Sections 11 and 12.	3298
T	Based on the EFD Extended Life Battery Test Report (Aspen document number 037-00042-001) extended internal and external (EBB58) battery life to 2200hrs or 3 years	3360
U	Removed references to "XM" to cover additional datalink weather sensors. Fixed typo in AFMS part number and updated the revision of the Installation Manual.	4251
V	Updated the Installation Manual references to the latest revision.	4392
W	Updated the Installation Manual references to the latest revision. Added instructions under CM Replacement for Angle of Attack (AOA). Changed Copyright from 2012 to 2015.	4486
X	Rev X not employed	N/A
Y	Added Aspen Evolution Backup Display (EFD1000 EBD).	4709
Z	Added support for the EFD1000 E5 Dual EFI and internal battery.	5445
AA	Added EFD1000/500 MAX part numbers in Section 11. Added "Degraded Mode" to troubleshooting table Section 13. Added words "or Audio" to Section 14, EFD Replacement. Corrected typographical errors. Truncated the revision history. Added FAA-recommended information regarding checks of heading performance after other modifications in section 2.	5707
AB	Revision Not Submitted	6130
AC	Revision Not Submitted	6158
AD	Extend internal battery and external battery (EBB-58) replacement interval to 2200 hours or 4 years (Section 11)	6169

THIS PAGE INTENTIONALLY LEFT BLANK

Table of Contents

1	INTRODUCTORY INFORMATION	5
2	SYSTEM DESCRIPTION AND INFORMATION ABOUT THE INTERFACE OF THE EFD1000/500 SYSTEM WITH THE AIRCRAFT	7
3	DESCRIPTION OF HOW THE EFD1000 SYSTEM OPERATES AND IS CONTROLLED, INCLUDING SPECIAL PROCEDURES AND LIMITATIONS	8
3.1	MAINTAINING SECURITY SAFEGUARDS WITH THE ASPEN CONNECTED PANEL.....	8
3.1.1	Physical Security	8
3.1.2	Operational Security.....	8
3.1.3	Security Safeguards Monitoring	9
3.1.4	Management Procedures	9
3.1.5	Maintenance Procedures for Maintaining Security Safeguards	9
4	SYSTEM OPERATION AND PROCEDURES FOR SYSTEM TESTING DURING GROUND RUNNING	9
5	SERVICING AND SCHEDULING INFORMATION.....	10
6	OVERHAUL PERIOD.....	10
7	COMMERCIAL PARTS	10
8	SPECIAL TOOLS	10
9	AIRWORTHINESS LIMITATIONS	10
10	DISTRIBUTION OF REVISIONS	10
11	PERIODIC MAINTENANCE AND CALIBRATION AND STORAGE LIMITATIONS.....	11
11.1	INSPECTION CHECKLIST	13
12	UNIT AND WIRING INSPECTION	14
12.1	INSPECTION CHECKLIST	15
13	TROUBLESHOOTING	17
14	REMOVAL AND REPLACEMENT	26
15	WIRING AND COMPONENT LOCATION DATA	32

1 Introductory Information

These Instructions for Continued Airworthiness (ICA) provides instructions necessary for authorized personnel to inspect and maintain the EFD500 and EFD1000 system installed by the EFD1000 AML-STC.

This document must be printed and included with the aircraft Instructions for Continued Airworthiness, and arranged for easy and practical use.

Description of the Appliances and its Systems and Installations:

The Aspen Avionics EFD1000 and EFD500 systems are multi-purpose displays. The EFD1000 contains an internal Air Data and Heading Reference System (ADAHRS) that is used to provide attitude, heading and air data for the display. The EFD500 is a variant of the EFD1000 and does not contain the internal ADAHRS. The EFD1000 (except the Evolution Backup Display (EBD) version) and the EFD500 come standard with an internal battery to provide a nominal 30 minute operation in the event of power loss. These batteries (except for the EFD1000 E5) are not designed to provide 30 minute operation under all foreseeable operating conditions, such as extreme cold temperatures where battery operation is not assured. The EFD1000 E5 internal battery does provide at least 30 minutes of operation under all foreseeable operating conditions. An optional (standard on EBD) Emergency Backup Battery (EBB) is available that will provide at least 30 minutes of operation under all foreseeable operating conditions. Typical EBB endurance at 25 deg C will exceed two hours when the battery is fully charged. When an Aspen Primary Flight Display (PFD) is installed, and the Emergency Backup Battery is connected to an EFD1000 Multi-Function Display (MFD), the legacy standby altimeter and airspeed indicators may be removed from the aircraft. When the EFD1000 EBD is installed as backup instruments to non-Aspen PFD, the legacy standby altimeter, airspeed and attitude indicators may be removed.

Additional equipment is normally installed in support of the displays, including the Remote Sensor Module (RSM), Configuration Module (CM), optional Emergency Backup Battery (as noted above) and optional Analog Converter Unit (ACU). Several external sensors can optionally be connected to the displays, including GPS systems, datalink weather receivers, the Aspen CG100 Gateway, WX-500 Stormscope, GTX330 and certain other ARINC 735A protocol TAS and TCAS I systems. The Avionik Straubing APS4A Altitude Preselect System can be installed for Altitude Preselect capability. The EFD1000 E5 has required connections to an RSM, CM, and one GPS receiver and optional connections to an ACU and one navigation receiver.

The EFD1000 system can be configured as a PFD or MFD or EBD or E5. In the PFD, EBD, or E5 configuration, the EFD1000 provides display of attitude, airspeed, altitude, direction of flight, vertical speed, turn rate, and turn quality. The system can provide display of navigation information, pilot-selectable indices (“bugs”), and annunciations to increase situational awareness and enhance flight safety.

The “Pro” and “Pilot” configuration are available in software version 2.1 and later. The EBD “Advanced” and “Basic” configuration are available in software 2.8.3 and later. The E5 is available in software E5 2.10 and later. The EFD1000/500 MAX displays are available in software 2.10 and

later. The Pro and EBD “Advanced” System can display WX-500 data, datalink weather products and traffic information from ARINC 735 compatible traffic systems. The Pilot and EBD Basic systems provide a moving map; however they do not provide an HSI or second GPS navigation. The E5 does not have a moving map but can display information from one GPS and one navigation receiver.

The EFD1000 can also be purchased in a multi-function display configuration with reversion capability to a Primary Flight Display. The EFD500 is a variant of the EFD family that does not include an ADAHRS. The EFD500 may only be purchased in a multi-function display configuration, and does not include reversion capability. The E5 is standalone with no second display option.

For additional information, refer to Section 3 of the EFD1000 and EFD500 SW v2.X Installation Manual, 900-00003-001 Rev BY or later. For additional information on the EFD1000 E5 see Section 3 of the EFD1000 E5 Flight Display Installation Manual, 900-00041-001 Rev () or later.

The following data may be necessary for maintenance or preventive maintenance:

Replacement Parts:	See Section 1 of the EFD1000 and EFD500 SW v2.X Installation Manual, document 900-00003-001 Rev BY or later (or for the EFD1000 E5, 900-00041-001 Rev () or later) for Aspen replacement parts. <i>For the APS4A Altitude Preselect System, contact:</i> Avionik Straubing Entwicklungs GmbH Flugplatzstr. 5 Atting D-94348 Germany www.avionik.de
Software Version Compatibility	Class III aircraft (typ. >6000 lbs. Maximum Gross Takeoff Weight (MGTOW), see AC 23.1309-1X) require a PFD containing RTCA DO-178B Level B software. Verify the software level on the EFD Data tag before installation. See Section 5.2, “ICA Software Compatibility” of the EFD1000 and EFD500 SW v2.X Installation Manual, document 900-00003-001 Rev BY or later.
Operating Instructions:	See the EFD1000 Aircraft Flight Manual Supplement (AFMS), document 900-00008-001 or the EFD1000 E5 Aircraft Flight Manual Supplement (AFMS), document 900-00038-001.
Wire Routing Locations:	See attachment to this document (part of the permanent aircraft records).
Wiring Diagrams:	See attachment to this document (part of the permanent aircraft records).
Special Tools	For bonding checks, use a milliohm meter such as an Extech 380460 Portable Precision Milliohm Meter or equivalent. It may be required to align the EA100 Adapter to the autopilot computer using a KTS-150 Test Set, a KTS-158 Test Set, a KTS-154 Test Set or equivalent and following the autopilot manufacturer’s procedure for aligning the gyro (KI-256) to the autopilot computer (these Test Sets are normally available at autopilot-qualified Bendix-King dealers). The EA100 Alignment Tool (acquired through the dealer ramp Section of the Aspen.com web site, see Tech Note 2010-10) will be used to manipulate the gyro pitch and roll signals and the autopilot Test Set will be used to measure the autopilot demodulated gyro voltages. In the case of the KFC225 the Remote Terminal Interface (normally available at autopilot-qualified Bendix-King dealers) will be required in place of the test sets.

	See Appendix E of the EFD1000 and EFD500 SW v2.X Installation Manual, document 900-00003-001 Rev BY or later or Appendix E of the EFD1000 E5 Dual Electronic Flight Instrument (EFI) Install Manual, 900-00041-001 Rev () or later for detailed information.
	It may be required to receive a WiFi signal from the CG100. A wireless-enabled device such as a laptop computer, iPad, iPhone or Android device will be suitable for this purpose.
Consumables	Loctite® 242® Threadlocker or equiv Dow Corning 738, MIL-A-46146 or equiv Pro-Seal PS 870B-1/2, MIL-PRF-81733D or equiv

2 System Description and Information about the Interface of the EFD1000/500 System with the Aircraft

The EFD1000 PFD, EFD1000 EBD, and EFD1000 E5 system is comprised of the Electronic Flight Display (EFD), Remote Sensor Module (RSM), Configuration Module (CM) and optional Analog Converter Unit (ACU or ACU2). Optionally one or two MFD displays of either the EFD500 or EFD1000 may be installed with an accompanied PFD system. An optional EA100 Adapter (autopilot attitude adapter) may be installed.

The EFD1000 PFD, EBD and E5 system provides display of attitude, airspeed, altitude, direction of flight, vertical speed, turn rate, and turn quality. The system may optionally provide display of navigation information through interfaces to GPS Receivers and/or VHF Navigation Receivers.

When interfaced with a compatible autopilot, the EFD1000 system provides heading and course datum information to the autopilot, which enables the autopilot to follow the Course and Heading values set by the pilot on the EFD1000.

If optional MFD displays are installed they can present terrain, traffic, weather, and WX-500 Stormscope data to the flight crew. The EFD1000 MFD can be used as backup instruments to the PFD supporting reversionary capabilities. The EFD500 presents MFD data, but cannot be used for backup or reversion.

The optional EA100 supplies pitch and roll stabilization signals to the autopilot. The article has no direct pilot controls.

The Avionik Straubing TSO'd APS4A is integrated with the EFD1000 and provides Altitude Preselect capability. The APS4A is not applicable to the EFD1000 E5.

The CG100 Gateway allows mobile devices to interface to other avionics through an EFD1000 MFD or EFD500 MFD.

NOTE: Other modifications to the aircraft could affect the EFD1000 PFD and MFD magnetic sensors. The EFD1000 PFD and MFD heading performance should be checked after other modifications. See Section 10.5.4, heading accuracy test in the EFD1000 and 500 SW 2.X Installation Manual, document 900-00003-001 revision BY or later.

3 Description of How the EFD1000 System Operates and is Controlled, Including Special Procedures and Limitations

The EFD1000 system is controlled by a switch marked “EFD1000 PFD” or “PFD”, “ASPEN” (for EBD system), “EFD” (for E5 system) and, (if installed) “EFD1000 MFD”. The system is ready to be operated when the initialization screen disappears, and the EFD1000 attitude and heading display is shown. See the EFD1000 Aircraft Flight Manual Supplement (AFMS), document 900-00008-001 or EFD1000 E5 Aircraft Flight Manual Supplement (AFMS), document 900-00038-001 regarding which appliances are installed, how the EFD1000 system operates, and is controlled, and special procedures and limitations.

An EBB58 Emergency Backup Battery is required for EBD installations and may be required in some EFD1000 MFD installation configurations if it is being used as any required secondary instruments.

See the attachment to this document (part of permanent aircraft records) for detailed interface information.

3.1 Maintaining Security Safeguards With the Aspen Connected Panel

The Aspen Connected Gateway is an appliance not required by 14 CFR Part 23 that permits bi-directional communication of data between wireless devices and the EFD1000 MFD. Security of the communication link to the EFD1000 MFD is important and appropriate for these instructions. Generally, the system automatically controls the security aspects of the communication link, however the operator has responsibility to assure adequate security when it comes to the human interaction.

3.1.1 Physical Security

The Connected Gateway System can be linked to several wireless devices at the same time. Only devices that are within range of the Wi-Fi signal can be linked. Therefore the devices that can be linked while in flight are limited to the devices in the aircraft. Physical security does not require maintenance or assurance for continued airworthiness. This is an operator consideration.

3.1.2 Operational Security

When the aircraft is in operation, only those systems used for Connected Gateway should be linked. Keep the password confidential. The operator should assure that only authorized devices have access to the Connected Gateway. Operational security does not require maintenance or assurance for continued airworthiness. This is an operator consideration. The password for the Connected Gateway Wi-Fi for a particular aircraft should be safeguarded and only supplied to those who are trusted. If an unexpected device is connected and a flight plan is sent, the choice is simply to reject the flight plan.

3.1.3 Security Safeguards Monitoring

If there are attempts to violate security rules while in flight, as shown by an unexpected candidate flight plan, reject the flight plan and turn off Aspen GTWY by the switch. Do not operate it until the security breach is addressed. Security safeguards monitoring does not require maintenance or assurance for continued airworthiness. This is an operator consideration.

3.1.4 Management Procedures

Measures should be established to prevent malicious introduction of unauthorized modifications to the wireless device, including the operating system, the hosted applications and the databases or data links. This might include maintaining a separate wireless device that is exclusively for aircraft use and limiting the number of applications loaded to those that are known to be non-malicious. Management procedures do not require maintenance or assurance for continued airworthiness. This is an operator consideration.

3.1.5 Maintenance Procedures for Maintaining Security Safeguards

With the EFD1000 or EFD500 MFD and the CG100 operating, display the CG100 status by going to the MFD Gateway page. Verify that Device: LINK STATUS CG100: is reported as LINKED. Use a wireless enabled device to search for the SSID of the installed Gateway. By default, the SSID is ASPENCG100. Verify that access requires a password. This also checks the functionality of the CG100 Gateway software and hardware.

4 System Operation and Procedures for System Testing During Ground Running

Refer to the EFD1000 AFMS, document 900-00008-001 or EFD1000 E5 AFMS, document 900-00038-001 for instructions on system operation. For System Testing refer to Section 10, Appendix E (EA100), Appendix F (A/P Source Select), Appendix G (APS4A) and Appendix H (CG100) of the EFD1000 and EFD500 SW v2.X Installation Manual, 900-00003-001 Rev BY or later. For the EFD1000 E5 refer to Section 10 and Appendix E (EA100) of the EFD1000 E5 Dual Electronic Flight Instrument (EFI) Install Manual, 900-00041-001 Rev () or later.

NOTE: Appendix H of document 900-00008-001 directs the user to another supporting document (900-00023-001, see "System Checkout") information for the CG100. This is because the primary document for the STC is document 900-00003-001, and information regarding support documentation will be in this document.

To check the functionality of the CG100 Gateway software and hardware, see Section 3.1.5.

5 Servicing and Scheduling Information

The EFD, RSM, ACU, ACU2, CM, EA100, APS4A, CG100, and EBB58 have no field serviceable components. Return defective units to Aspen Avionics or an authorized dealer. No equipment is required for servicing.

Recommended times for cleaning, inspecting, testing lubricating and adjusting each component of the EFD1000 System. See the Periodic Maintenance and Calibration Section.	
EA100	Verify the operation of the internal autopilot disconnect relay annually (See Section 11)
Internal backup battery	Inspection every twelve months (See Section 11)
EBB58 Emergency Backup Battery	Inspection every twelve months (See Section 11)
A/P Source Select switch	Verify operation annually (See Section 11)
All other components	Refer to Section 12 for inspection requirements.

6 Overhaul Period

None required.

7 Commercial Parts

There are no commercial parts in the installed EFD1000/500 system.

8 Special Tools

For bonding checks, use a milliohm meter such as an Extech 380460 Portable Precision Milliohm Meter or equivalent.

It may be required to align the EA100 Adapter to the autopilot computer using a KTS-150 Test Set, a KTS-158 Test Set, a KTS-154 Test Set or equivalent and following the autopilot manufacturer's procedure for aligning the gyro (KI-256) to the autopilot computer. The EA100 Alignment Tool will be used to manipulate the gyro pitch and roll signals and the autopilot Test Set will be used to measure the autopilot demodulated gyro voltages. In the case of the KFC225 the Remote Terminal Interface will be required in place of the test sets.

9 Airworthiness Limitations

There are no Airworthiness limitations associated with the installation of this appliance. The Airworthiness Limitations Section is FAA approved and specifies maintenance required under 14 CFR § 43.16 and § 91.403 unless an alternate program has been FAA approved.

10 Distribution of Revisions

Notification of changes to this ICA will be sent to all owners on record. The changed document will then be available in the Dealer Ramp section at www.aspenavionics.com. Paper copies are available on request, contact Aspen Avionics at www.aspenavionics.com.

11 Periodic Maintenance and Calibration and Storage Limitations

All maintenance is considered “ON CONDITION” unless otherwise noted in this ICA. The EFD Internal battery and the Emergency Backup Battery must be replaced in the interval identified below. There are no other storage limitations.

EBB58 Emergency Backup Battery (use with EFD P/N 910-00001-002, -012, -007, and -017)

The EBB58 Emergency Backup Battery when installed must be visually inspected and tested as described below once every 12 months and biannually (every 6 months) after 3 years (from date of installation) to ensure it meets the minimum 30-minute requirement for powering the EFD1000 MFD and EBD under all foreseeable conditions. The EBB58 must be replaced every 4 years (from the date of installation) or 2200 flight hours (from the time of installation) (whichever occurs first), or if it fails the following visual or operational tests.

Remove the EBB from the tray and visually inspect for the following:

- Leakage from the battery especially around the metal seams
- Evidence of water contamination
- Evidence of corrosion

If any of the above issues are noted return the EBB58 to Aspen Avionics for repair.

Re-install the battery and check the battery capacity as follows: (this test must be run at room temperature approximately 25° C)

- Turn on the EFD1000 MFD or EBD
- Press MENU Key
- Select POWER SETTINGS, Main Menu page
- Press the BATTERY line select key

BAT LEVEL IN --.-- will be displayed for a short period of time as battery capacity is being measured. This could take up to 10 minutes if the ambient temperature is below 0° C.



BAT LEVEL
IN 0:13

Once the capacity is measured ON BAT XX% REM will be displayed.



ON BAT
85% REM

The “ON BAT” indication must read a minimum of 80% to continue. If the battery capacity is below 80% then the battery should be charged by returning the MFD or EBD to aircraft power. The EBB will charge as long as the display is turned on and aircraft power is supplied.

With the battery displaying greater than 80% charge set a timer for one (1) hour. After the one hour time has elapsed the MFD or EBD must still be operating on battery. If the EBB will not

supply the minimum 1 hour operating time or fails to charge above 80% return the battery to Aspen Avionics for repair.

Instructions for battery replacement are contained in Section 12.

Following the battery endurance test and while operating on battery power, switch the “EBB EMER DISC” switch to “DISC”; verify the display powers OFF. Return the “EBB EMER DISC” switch to “NORM”; verify the display powers ON and is on battery power.

Switch the MFD or EBD back to aircraft power and recharge the EBB to 80% or greater prior to release to service.

EFD Internal Battery (EFD P/N 910-00001-001, -003, -004, -011, -013 and 900-00101-001)

The internal back-up battery in the EFD must be tested once every 12 months and biannually (every 6 months) after 3 years (from date of installation) to ensure it operates properly. Each EFD with an internal battery must have the battery replaced every 4 years or 2200 hours, or if it fails the following operational test.

This test must be run at room temperature approximately 25° C.

- Turn on the EFD1000 or EFD500
- Press MENU Key
- Select POWER SETTINGS page from the Main Menu
- Press the BATTERY line select key

BAT LEVEL IN --.-- will be displayed for a short period of time as battery capacity is being measured. This could take up to 10 minutes if the ambient temperature is below 0° C.



BAT LEVEL
IN 0:13

Once the capacity is measured ON BAT XX% REM will be displayed.



ON BAT
85% REM

The “ON BAT” indication must read a minimum of 80% to continue. If the battery capacity is below 80% then the battery should be charged by returning the EFD to aircraft power. The battery will charge as long as the MFD is turned on and aircraft power is supplied.

With the battery displaying greater than 80% charge set a timer for 30 minutes (40 minutes for the E5). After the 30 minute (40 min for E5) time has elapsed the EFD must still be operating on battery. If the internal battery will not supply the minimum 30 minutes (40 min for E5) operating time or fails to charge above 80%, replace the battery and return the failed battery to Aspen Avionics.

Instructions for battery replacement are contained in Section 14.

Switch the EFD back to aircraft power and recharge the internal battery to 80% or greater prior to release to service.

Instructions for battery replacement are contained in Section 14. Contact customer service at Aspen Avionics or an authorized Aspen Avionics Dealer for a replacement battery.

EA100 Autopilot Disconnect (if the EA100 is installed)

The ability of an EA100 to disconnect the autopilot must be tested annually. The test is accomplished in the following manner:

Turn on the PFD, or EBD, or E5 and all MFD systems. Verify the "A/P AHRS FAIL" light extinguishes. Engage the autopilot and then pull the "A/P AHRS" circuit breaker. If the autopilot disengages immediately and the A/P AHRS light simultaneously illuminates, then the test was successful. Restore the circuit breaker. If the autopilot fails to disengage then arrange for repair of the EA100 or associated wiring.

A/P Source Select (if installed)

The switch must be tested annually. The test is accomplished in the following manner:

Turn on the PFD and all MFD systems. Engage the autopilot and verify the PFD heading bug will steer the HDG mode of the autopilot. Disconnect the autopilot. Press the MFD "REV" button and then momentarily push the A/P Source Select switch to the MFD REV position. Engage the autopilot and verify the reverted MFD heading bug will steer the HDG mode of the autopilot.

EFD Display Backlight

The EFD display backlight has a median expected life of 50,000 operating hours. Replacement of the lamp is on-condition as it may last longer or shorter than 50,000 hours. It is up to the operator to determine whether the backlighting has become too dim for its intended use.

ACU, ACU2, RSM, APS4A, CM, CG100

The ACU, ACU2, RSM, APS4A, CG100 and the Configuration Module require no periodic maintenance or calibration.

11.1 Inspection Checklist

FAR 43.15, Additional performance rules for inspections, Para. (c)(1) Annual and 100-hour inspections, requires "Each person performing an annual or 100-hour inspection shall use a checklist while performing the inspection." Depending on the options and thus the associated complexity, it may be advantageous to prepare a checklist to be used when performing an Annual or 100-hour inspection. For all installations, the information will be found in Sections 11 and 12 of this document. Those items marked "If Installed" means that the inspection should only be conducted if the equipment is installed in the aircraft. Refer to the EFD1000 Aircraft Flight Manual Supplement, document 900-00008-001 or EFD1000 E5 Aircraft Flight manual Supplement, document 900-00038-001 for this aircraft to determine the equipment installed.

Section 11 Checklist

1. Check the EBB58 battery (if installed) in accordance with Section 11 of this document.
2. Check the EFD internal battery in accordance with Section 11 of this document. Note that each EFD has a battery, unless the EFD1000 MFD or EBD which have an EBB58 battery.
3. Check the EA100 Autopilot disconnect switch (if installed) in accordance with Section 11 of this document.
4. Check the A/P Source Select switch (if installed) in accordance with Section 11 of this document.
5. Verify Security Safeguards in accordance with Section 3.1.5 of this document.

12 Unit and Wiring Inspection

All units, brackets, installation hardware and wiring of the EFD1000 system should be checked as defined below during annual inspection. Items found to be defective should be repaired or replaced prior to returning the aircraft to service. The performance of this inspection should not create the need for additional protective treatment (Alodine, paint, etc) of surfaces within the aircraft.

EFD Inspection

The EFD(s) should be inspected for damage and their operation should be verified using documents identified in Section 1 of these ICA's. The EFD wiring, pneumatic tubing, and quick disconnects should be checked for integrity, damage, chafing, or excessive wear. The EFD braided bonding strap should be checked for proper termination at the EFD and aircraft grounding point to maintain HIRF and Lightning compliance.

Verify ≤ 3 milliohms from EFD ground stud to airframe ground. The installation of the EFD should be inspected for corrosion on the EFD and the structure it is mounted on. The fasteners should be inspected for tightness and general condition.

ACU/ACU2 Inspection - if installed

The ACU should be inspected for damage and its operation should be verified using documents identified in Section 1 of these ICA's. ACU wiring should be checked for damage, chafing, or excessive wear. Verify ACU chassis bonding from the face of the unit (connector side) to airframe ground is ≤ 3 milliohms to maintain HIRF and Lightning compliance. The installation of the ACU should be inspected for corrosion on the ACU and the structure it is mounted on. The fasteners should be inspected for tightness and general condition.

RSM Inspection

The RSM(s) should be visually inspected for damage and wear on the lightning strip. RSM wiring should be checked for damage, chafing, or excessive wear. Verify RSM doubler plate bonding from the ground stud to airframe ground is ≤ 3 milliohms to maintain HIRF and Lightning compliance. The RSM installation and doubler should be inspected for corrosion on the RSM, the

RSM shim (optional), the fuselage skin, and the doubler. The installation should be inspected for cracks in the fuselage, and loose or damaged fasteners.

Configuration Module Inspection

The Configuration Module(s) should be checked for damage. The Configuration Module wiring should be checked for damage, chafing, or excessive wear.

EA100 Inspection – if installed

The EA100 should be inspected for damage and its operation should be verified using documents identified in Section 1 of this document. The EA100 wiring should be checked for damage, chafing, or excessive wear. Verify EA100 chassis bonding from the face of the unit (connector side) to airframe ground is ≤ 3 milliohms to maintain HIRF and Lightning compliance. The installation should be inspected for corrosion on the EA100 and the structure it is mounted on. The fasteners should be inspected for tightness and general condition.

EBB58 Inspection –if installed

The EBB58 Emergency Backup Battery should be inspected for damage to the battery and mounting tray. Battery operation should be verified using Section 9 of this ICA. Verify ≤ 3 milliohms from mounting tray to airframe ground. The wiring should be checked for damage, chafing, or excessive wear.

APS4A Inspection– if installed

The APS4A should be inspected for damage and its operation should be verified using documents identified in Section 4 of this document. The APS4A wiring should be checked for damage, chafing, or excessive wear. Verify APS4A chassis bonding from one of the cover retaining cap screws to airframe ground is ≤ 3 milliohms to maintain HIRF and Lightning compliance. The installation should be inspected for corrosion on the APS4A and the structure it is mounted on. The fasteners should be inspected for tightness and general condition.

CG100 Inspection– if installed

The CG100 should be inspected for damage and its operation should be verified using documents identified in Section 4 of this document. The CG100 wiring should be checked for damage, chafing, or excessive wear. Verify CG100 chassis bonding from face of the unit (connector side) to airframe ground is ≤ 3 milliohms to maintain HIRF and Lightning compliance. The installation should be inspected for corrosion on the CG100 and the structure it is mounted on. The fasteners should be inspected for tightness and general condition.

12.1 Inspection Checklist

FAR 43.15, additional performance rules for inspections, Para. (c)(1) Annual and 100-hour inspections, requires "Each person performing an annual or 100-hour inspection shall use a checklist while performing the inspection." Depending on the options and thus the associated complexity, it may be advantageous to prepare a checklist to be used when performing an Annual or 100-hour inspection. For all installations, the information will be found in Sections 11 and 12 of this document. Those items marked "If Installed" means that the inspection should

only be conducted if the equipment is installed in the aircraft. Refer to the EFD1000 Aircraft Flight Manual Supplement, document 900-00008-001 for this aircraft to determine the equipment installed.

Section 12 Checklist

1. Inspect the EFD(s) for damage and their operation in accordance with Section 12 of this document.
2. Inspect the ACU or ACU2 (if installed) for damage and its operation in accordance with Section 12 of this document.
3. Inspect the RSMs for damage and wear in accordance with Section 12 of this document.
4. Inspect the Configuration Module(s) for damage in accordance with Section 12 of this document.
5. Inspect the EA100 (if installed) for damage and its operation in accordance with Section 12 of this document.
6. Inspect the EBB58 (if installed) for damage in accordance with Section 12 of this document.
7. Inspect the APS4A (if installed) for damage and its operation in accordance with Section 12 of this document.
8. Inspect the CG100 (if installed) for damage and its operation in accordance with Section 12 of this document.

13 Troubleshooting

NOTE:

For more information about recognizing malfunctions, see the checkout procedure Sections 10 and 11 in the EFD1000 and EFD500 SW v2.X Installation Manual, 900-00003-001 Rev BY or later or EFD1000 E5 Dual Electronic Flight Instrument (EFI) Install Manual, 900-00041-001 Rev () or later.

EFD1000 Startup Page Faults (SW v2.0 and above)

Malfunction & How to Recognize the Malfunction	Cause	Remedy
IOP initialization failure	a) Fail b) System reboots after IOP test	a) Replace EFD b) Replace EFD
ARINC initialization failure	a) Fail	a) Replace EFD
RS232 initialization failure	a) Fail	a) Replace EFD
Config Module initialization failure	a) Fail b) Wrong CM version c) System reboots after Config Module Test d) displays “Initializing” for more than 20 seconds	a) Check Config Module wiring. Replace Config Module. b) Install correct SW version CM. c) v2.0 or v2.1 display installed with a v2.2 CM. Install correct CM or EFD. d) Config Module unplugged or mis-wired.
RSM initialization failure	a) Fail (x)	a) Check RSM to PFD wiring for shorts or opens. Repair or replace RSM. Repair or replace PFD.
IMU initialization failure	a) Fail	a) Replace EFD
ADC initialization failure	a) Fail	a) Replace EFD
ADAHRS initialization failure	a) Fail b) “Initializing” for more than 3 minutes c) “Initializing” for more than 3 minutes with a RSM Fail above.	a) Replace EFD b) Remove Pitot and Static line from back of EFD and reboot. If problem still exists then replace the EFD. If problem clears then repair Pitot or Static obstruction/kink. c) Repair RSM wiring or replace RSM.

EFD1000 General Faults (SW v2.0 and above)

Malfunction & How to Recognize the Malfunction	Cause	Remedy
Display does not power on (Note: there can be up to a 20 second delay from the application of power to a visible display)	a) EFD missing A/C power b) EFD may have been improperly shut down c) EFD missing A/C ground d) EFD is defective	a) Check EFD circuit breaker, EFD on/off switch on panel, wiring, and A/C battery voltage > 11.5 volts. b) Switch unit off using “REV” button or “SHUT DOWN” command from Main Menu page 6. c) Check wiring to EFD d) Repair or replace EFD
Display does not power off (Note: EFD will switch to battery if airspeed is greater than 30kts.)	a) Airspeed is above 30kts b) EFD may have been switched to internal battery c) EFD may have been improperly shut down d) EFD is defective	a) Normal operation b) Switch unit off using “REV” button or “SHUT DOWN” command from Main Menu page 6. c) Hold “REV” button for 20 seconds or unplug EFD internal battery for 3 seconds d) Repair or replace EFD
Display flashes on/off, black/white or blue/white repetitively	a) Configuration Module unplugged or miswired b) RSM or CM wiring short c) Configuration module defective d) EFD defective	a) Check CM plug and wiring from EFD to CM b) Verify RSM pin 6 or CM pin 1 is not shorted to aircraft ground or another pin. c) Repair or replace CM d) Repair or replace EFD
“CONFIG MODULE LINK FAIL” message (SW v1.X)	a) Configuration Module unplugged or mis-wired b) Configuration module defective c) PFD defective	a) Check CM plug and wiring from PFD to CM b) Repair or replace CM c) Repair or replace PFD
“INITIALIZING” message for more than 60 seconds (SW v1.X)	a) RSM to PFD communication lost b) RSM failed c) PFD failed	a) Check RSM to PFD wiring for shorts or opens. b) Repair or replace RSM c) Repair or replace PFD
“RSM LINK FAIL” message (SW v1.X)	a) RSM to PFD communication lost b) RSM failed c) PFD failed	a) Check RSM to PFD wiring for shorts or opens. b) Repair or replace RSM c) Repair or replace PFD
“WRONG CONFIG MODULE” message (SW v1.X)	a) PFD is at one software level and config module is at a different software level	a) Convert config module per appropriate service bulletin.

Malfunction & How to Recognize the Malfunction	Cause	Remedy
ALTIMETER, AIRSPEED, VSI FAIL (RED-X)	<ul style="list-style-type: none"> a) Air data sensor has not had sufficient warm-up time. b) Pitot/static lines reversed c) Air data sensor failed 	<ul style="list-style-type: none"> a) Allow up to 20 minutes at temps below -20°C for flags to clear b) Connect pitot line to “P” port and static line to “S” port on EFD c) Repair or replace EFD
ATTITUDE FAIL or DIRECTION FAIL (RED-X) (Note: Attitude flags could take up to 3 minutes to clear at temps below -20 °C)	<ul style="list-style-type: none"> a) AHRS sensor has not completed initialization. b) RSM failed/data missing. c) Pitot and/or Static lines crossed, unplugged, or blocked. d) EFD is defective 	<ul style="list-style-type: none"> a) Allow up to 3 minutes for AHRS to initialize. b) Check RSM to EFD wiring. Repair or replace RSM. c) Correct pitot/static plumbing issue. d) Repair or replace EFD.
ATTITUDE FAIL and DIRECTION FAIL associated with “CHECK PITOT HEAT” message	<ul style="list-style-type: none"> a) In Flight, Normal if pitot blockage due to ice or other. b) On Ground, Normal if GPS reception is marginal and GPS GS ramps above 50Kts intermittently. 	<ul style="list-style-type: none"> a) Use pitot heat or check pitot system for blockage. b) No further action required unless message is due to faulty GPS system, then repair GPS system.
DEGRADED MODE (sw 2.10 and later) – GPS groundspeed is above 50kts and airspeed is below 30kts	<ul style="list-style-type: none"> a) In Flight, Normal if pitot blockage due to ice or other. 	<ul style="list-style-type: none"> a) Use pitot heat or check pitot system for blockage.
	<ul style="list-style-type: none"> b) On Ground, Normal if GPS reception is marginal and GPS GS ramps above 50Kts intermittently. 	<ul style="list-style-type: none"> b) No further action required unless message is due to faulty GPS system, then repair GPS system.
CROSS CHECK ATTITUDE message (yellow) (also see sluggish AHRS performance troubleshooting)	<ul style="list-style-type: none"> a) If it occurred on system start. b) Normal after abrupt maneuvers on ground or in air 	<ul style="list-style-type: none"> a) RESET AHRS b) RESET AHRS

Malfunction & How to Recognize the Malfunction	Cause	Remedy
Red Slash through Navigation Sensor (i.e., GPS1, NAV2)	<ul style="list-style-type: none"> a) GPS or VLOC receiver turned off. b) GPS does not have a valid "TO" waypoint and position c) GPS or VLOC receiver failed d) ACU not powered e) Wiring fault between sensor and ACU or EFD f) ACU to EFD wiring fault. g) ACU is defective. h) EFD is defective. 	<ul style="list-style-type: none"> a) Turn on GPS or VLOC receiver b) Allow GPS to acquire a position and enter a flight plan or Direct To c) See GPS/VLOC manufacturer's instructions for troubleshooting d) Check ACU circuit breaker e) Check wiring between GPS/VLOC and ACU or EFD f) Check ACU circuit breaker, check ACU to EFD A429 wiring and ACU to sensor wiring g) Repair or replace ACU h) Repair or replace EFD
GPS1 or GPS2 selection not available on Display (GNS430/GNS530/GNS480 only)	<ul style="list-style-type: none"> a) GPS receiver turned off b) GPS does not have a valid "TO" waypoint and position c) GNS CDI is selected to VLOC. d) GPS to EFD A429 wiring issue. e) GPS defective. f) EFD defective. 	<ul style="list-style-type: none"> a) Turn on GPS and initialize b) Allow GPS to acquire a position and enter a flight plan or Direct To c) Verify the GNS CDI is selected to GPS. d) Check A429 wiring for shorts, opens or crossed A and B lines. e) Repair or replace GPS f) Repair or replace EFD
Autopilot or analog NAV/GPS inoperative	<ul style="list-style-type: none"> a) ACU chassis not grounded b) ACU not powered c) ACU to sensor wiring d) ACU to EFD wiring e) ACU fault f) EFD fault 	<ul style="list-style-type: none"> a) Ground ACU chassis to airframe ground b) Check ACU circuit breaker and power/grounds c) Check ACU to sensor wiring d) Check ACU to EFD A429 wiring e) Repair or replace ACU f) Repair or replace EFD

Malfunction & How to Recognize the Malfunction	Cause	Remedy
<p>“ERRONEOUS CALIBRATION VALUES” message during RSM Cal (SW v2.0 and later) or Excessive Heading errors in one quadrant, or errors that are higher than actual in some quadrants and lower than actual in other quadrants.</p>	<p>a) RSM is tilted more than allowed per Section 6 of this manual b) Poor RSM calibration c) RSM calibrated too close to buildings or ferrous objects d) Ferrous hardware used to mount RSM e) Airframe or external magnetic interference</p>	<p>a) Shim RSM to within limits defined in Section 6 of this manual b) Re-run RSM calibration at constant rate turns on flat ground. c) Re-run RSM calibration away from buildings and other ferrous objects d) Only non-ferrous screws, nuts, washers may be used on RSM e) Check for magnetized areas on airframe close to RSM. Verify no ferrous hardware is near RSM. Degauss magnetized area(s)</p>
<p>Sluggish or Poor AHRS (ADI) performance Poor AHRS performance in steep bank turns Sluggish compass card (Note: may or may not be associated with “Cross Check Attitude” message)</p>	<p>a) RSM magnetic interference b) RSM has become magnetized. c) “Pitch Attitude Trim” or “Panel Tilt Pitch Compensation” adjustment made without performing a subsequent RSM Calibration. d) Pitot and/or Static line connections at EFD blocked, kinked, or unplugged. e) Normal after abrupt maneuvers.</p>	<p>a) Survey RSM location using handheld compass per Section 6.9.1. Verify there are no cabin speakers within 3ft of RSM. Degauss any areas found to be magnetized or remove magnetism by other methods. b) With power removed from EFD1000 system degauss RSM and general area using degausser. c) Perform an RSM Calibration per Section 10.5.2 d) Check pitot/static connections and plumbing for blockage. Check IAS and ALT sensor per Section 10. e) Perform AHRS Reset</p>
<p>Excessive Heading Lead / Lag during or after turns (>7°)</p>	<p>Magnetic Interference</p>	<p>Verify that all steps have been accomplished to remove magnetic interference (see section 6.9.4), then contact an Aspen Field Service Engineer</p>

Malfunction & How to Recognize the Malfunction	Cause	Remedy
Autopilot has lateral offset in GPSS or APPR mode (HDG Bug may also be out of center)	a) Autopilot roll “null” centering out of adjustment	a) Follow the autopilot manufacturer’s guidelines for adjusting roll “null” centering
Century II/III autopilot performance poor in all modes	a) Value of R1 set incorrectly	a) Follow the autopilot manufacturer’s instructions for checking NAV intercept angle. Larger value for R1 will raise angle and smaller value of R1 will lower intercept angle. See Tech Note 2009-06.
OAT Display dashed	a) Wiring fault between EFD and RSM b) RSM is defective	a) Check wiring b) Repair or replace RSM
WIND vector, velocity, and direction display dashed (Note: wind readout will dash when velocity is < 10 kts)	a) Groundspeed < 20kts b) No GPS ground track c) Airspeed failed	a) Normal operation b) GPS not computing GTK c) See AIRSPEED FAIL troubleshooting procedure
OBS mode inoperative on GPS	a) GPS A429 IN bus configured wrong b) ARINC 429 “A” and “B” lines reversed	a) See Figure 9.27 for GPS configuration notes b) Correct wiring error to GPS A429 IN bus
“CROSS LINK FAILURE” message	a) PFD or MFD not powered up b) PFD or MFD inter-system bus wiring fault c) PFD or MFD is defective	a) Power up all EFD displays b) Check wiring per diagrams in Section 9 c) Repair or Replace defective EFD
“DATABASE FAILURE” message	a) Data Card (microSD) is not inserted in MFD display. b) Wrong Data Card inserted. c) Data Card is bad d) MFD card slot is defective	a) Insert Data Card in display b) Insert correct Data Card See Section 1 for authorized database part numbers c) Replace data card with new d) Repair or replace MFD display
“Database Init” message	a) Database is missing or files are missing from card	a) Insert functional database card

Malfunction & How to Recognize the Malfunction	Cause	Remedy
"TERRAIN FAIL" message	a) Data Card not inserted b) Data Card failed c) Heading fail d) GPS position fail e) Altitude fail	a) Insert valid MFD Database b) Insert valid MFD Database c) Verify EFD1000 MFD Direction Indicator is valid and repair if needed. EFD500 MFD inter-communication bus to PFD may have failed or is not configured. d) Verify GPS has good position data e) Verify EFD1000 Altitude is valid. EFD500 MFD intercommunication bus to PFD may have failed or is not configured.
"TFC FAIL" message	a) Traffic sensor is configured but not valid.	a) Verify traffic processor is turned on and is operational.
Dedicated Traffic Display page messages	See AFMS or pilots guide	
Dedicated WX500 Display page messages	See AFMS or pilots guide	
Dedicated Weather Display page messages	See AFMS or pilots guide	
"RSM GPS" message	a) Message is on MFD and a -002 or -003 RSM is installed. b) New RSM installation. c) Wiring issue between EFD and RSM. d) RSM GPS engine has failed.	a) Set RSM GPS Enable to DISABLE in installation menu. b) New RSM installations may need to acquire an almanac and could require up to 15 minutes to clear. c) Check RSM pins 1 and 2 for continuity to EFD. d) Replace RSM.

System Troubleshooting –continued

Fault	Cause	Corrective Action
EA100		
A/P AHRS FAIL lamp is never illuminated when the EA100 circuit breaker is engaged and the circuit is closed and energized (press to test fails)	a) Probable lamp failure. The A/P AHRS FAIL lamp power source is the autopilot circuit.	a) Verify the autopilot circuit breaker is not tripped. b) Check wiring for the lamp and autopilot circuit breaker. If OK, replace the A/P AHRS FAIL lamp.
A/P AHRS FAIL lamp is illuminated whenever the EA100 circuit breaker is engaged and the circuit is closed and energized.	a) EA100 is not functioning.	a) Verify the EFD1000 IP ADDR/SUBNET MASK/PORT is set correctly (see “Configuration” in Appendix E of this manual). b) Verify the EFD1000 has software version 2.2.2 or later. c) Verify the A/P AHRS circuit breaker is not tripped. Check the wiring to the EA100. If OK, replace the EA100. d) Normal operation if EA100 Alignment Tool is in use. Use “Engage Relay” to close relay contact and turn off light.
Autopilot has lateral offset in GPSS or APPR mode (HDG Bug may also be out of center)	a) Autopilot roll “null” centering out of adjustment.	a) Follow the autopilot manufacturer’s guidelines for adjusting roll “null” centering.
APS4A		
Altitude Preselect function is inoperative when the autopilot altitude hold function is correct.	a) Failure of the APS4A, or b) Failure of the EFD1000 ground assert to the APS4A when the altitude alerter reaches the selected altitude.	a) Verify the APS4A circuit breaker is not tripped. b) Check wiring and the presence of the ground assert when the altitude alerter reaches the selected altitude. Use ground elevation for the altitude alerter selection.
Altitude Preselect function is inoperative when the autopilot altitude hold function is not correct.	a) Failure of the autopilot.	a) Refer to autopilot troubleshooting procedures.

Fault	Cause	Corrective Action
CG100		
<p>The SSID “AspenCG100” not broadcast</p>	<p>a) CG100 not powered on b) CG100 antenna disconnected c) CG100 is defective</p>	<p>a) Repair wiring/switch/circuit breaker. b) Verify antenna is connected or coax is ok if using remote antenna. c) Before replacing the CG100 check to see if the LEDs are lit under the SD card cover. If the LEDs are not lit then the CG100 has malfunctioned. Replace CG100.</p>
<p>The wireless device does not link to the CG100.</p>	<p>Wrong password</p>	<p>If the correct password cannot be located, the CG100 must be returned to Aspen for repair.</p>
<p>MFD will not communicate with CG100</p> <ul style="list-style-type: none"> • “Not Linked” message on MFD Gateway Page • GTWY Version Number reports UNKNOWN 	<p>a) CG100 IP Address wrong b) MFD IP Address wrong c) Ethernet wiring bad</p>	<p>a) Use the “Aspen Flight Connect App” to set IP Address b) Set MFD IP Address to 192.168.28.12 for MFD1000 or 192.168.28.10 for MFD500 c) Check Ethernet wiring</p>
<p>GPS will not communicate with CG100</p> <ul style="list-style-type: none"> • GPS1 or GPS2 “Not Available” message on MFD Gateway Page 	<p>a) GPS turned off or not beyond Test Page b) Wrong MFD RS232 Ports configured for GPS Type 4/5 c) RS232 wiring issue between MFD and GPS</p>	<p>a) Turn on GPS and press “OK” twice b) Verify the MFD has GPS TYPE 4 or 5 set on the proper RS232 ports. c) Check GPS to MFD wiring.</p>

14 Removal and Replacement

This section provides instructions for removal and replacement of LRUs that have been previously installed in the aircraft. No special tools are required for the removal and replacement of any system LRUs. If an LRU is found to be defective it should be removed and returned to Aspen Avionics for repair or replacement.

Fastener Identification and Discard Recommendations:

The fasteners for the components identified below are identified in the EFD1000 and EFD500 SW v2.X Installation Manual, 900-00003-001 Rev BY or later and EFD1000 E5 Dual Electronic Flight Instrument (EFI) Install Manual 900-00041-001 Rev () or later. If the fasteners are deformed in any way they should be replaced.

EFD Removal

Verify power is off. Carefully insert a flat blade screwdriver into the locking mechanism on the top center of the EFD. While gently prying pull back the top of the EFD and extract from bracket. Remove nut securing braided ground strap to EFD. Remove pitot and static quick connectors (EFD1000 only) by pulling back outer spring loaded locking sleeve while unplugging connectors. To remove 44 pin D-sub connector unscrew both jackscrews fully and pull connector straight back.

EFD Replacement

Verify power is off. Install 44 pin D-sub connector and tighten jackscrews until connector is fully seated. Install pitot and static lines (EFD1000 only) to back of EFD by firmly pressing the fitting until fully seated (pitot and static quick connectors are keyed and cannot be crossed). Gently pull on connector to ensure proper connection. Connect braided bonding strap to EFD with nut. Insert bottom of EFD into bracket and pivot top forward until it locks into place on bracket.

Using section 10.6 of 900-00003-001 Rev BY or later (or 900-00041-001 Rev () or later, E5 only), verify all system interfaces are functional. Verify proper bonding per Section 10.1.2 (10.2 for E5). Perform a System Leak Test (Section 10.6.3, EFD1000 systems only) and Sonalert or Audio Test (Section 10.6.11, PFD and EBD only).

EFD Battery Replacement

EFD battery replacement must only be performed by a properly certified individual or facility.

There are two types of replacement batteries each with its' own unique connector:

- Battery Assy 413-00001-001 is specifically for the EFD1000 A-05-110-00 Rev A and the 910-00001-001 Rev ().
- Internal Battery Pack 409-00003-001 is for all other internal battery TSO'd EFDs.
- Internal Battery Pack 409-00003-002 is for all EFD1000 E5 PMA'd EFDs.

Remove the EFD from the aircraft panel as described above. Remove the two screws (one on each end) securing the oval-shaped battery cover plate to the rear of the EFD.

Use caution when removing the battery:

The Inner Battery Gasket may extend partially into the battery cavity as shown in the image below. Carefully remove the battery to not disturb the gasket. *If damaged, the Inner Battery Gasket cannot be replaced in the field and the unit must be returned to the factory.*

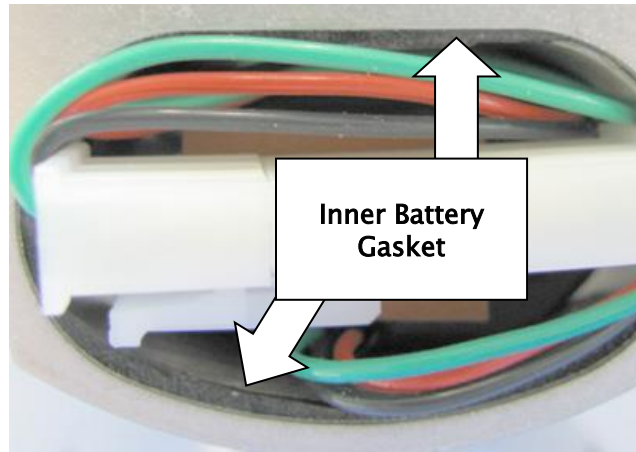

Unplug the battery connector from the IO Harness connector. Remove the old battery and install the new battery in the EFD. Then plug in the battery connector to the IO Battery Harness connector.

See the images below for connector placement and wire routing for each Battery type. To prevent pinching/shorting of wires, the wires must be routed as shown.

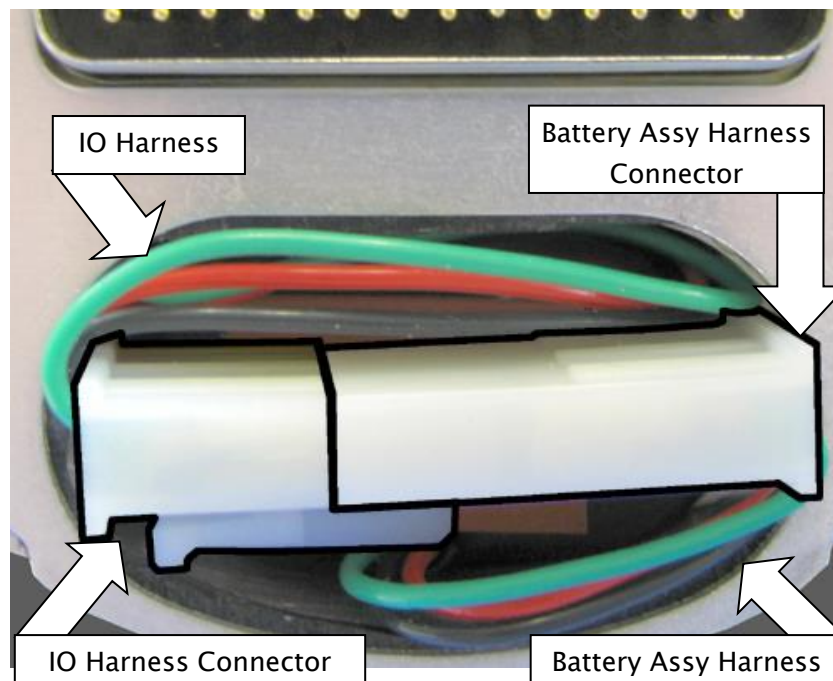

409-00003-00x Internal Battery Pack Connector & Wire Positioning

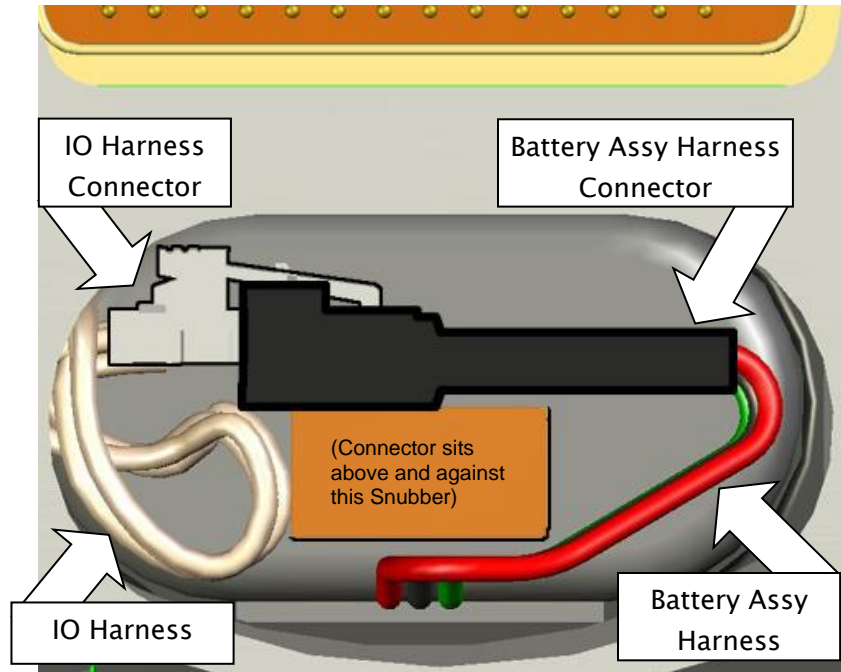

413-00001-001 Battery Assy Connector & Wire Positioning

Clean the threads of the two screws used to secure the battery cover. Place a small amount of Loctite® 242 on the threads of the cover screws, then position the cover plate, install the cover screws and torque to 12 in-lbs. Reinstall into panel as instructed in the EFD Replacement section above and then test the EFD.

ACU/ACU2 Removal

Verify power is off. Remove ACU by unscrewing the jackscrews of all D-sub connectors. Gently remove the connectors by pulling straight out. Remove the six (6) 6-32 mounting screws securing the ACU to the aircraft and remove unit from aircraft.

ACU/ACU2 Replacement

Verify power is off. Install ACU in mounting location and install six (6) 6-32 mounting screws through holes in ACU mounting tabs. Tighten to 12 in-lbs. Install all D-sub connectors securing each with the two jackscrews per connector.

Verify proper bonding per Section 10.1.2, then perform post installation tests in Sections 10.6.6, 10.6.7, 10.6.9, 10.6.10 of the EFD1000 and EFD500 SW v2.X Installation Manual 900-00003-001 Rev BY or later. For the E5, verify bonding per Section 10.2 and perform post install tests in Sections 10.6.5 thru 10.6.10 of the EFD1000 E5 Dual Electronic Flight Instrument (EFI) Install Manual 900-00041-001 Rev () or later.

CAUTION: *The RSM is very sensitive to local magnetic fields. Do not use a magnetic tipped screw driver when removing and replacing the RSM.*

RSM Removal

Verify power is off. It will be necessary to gain access to the underside of the RSM mounting location in order to unplug the RSM connector. Unscrew RSM electrical connector from inside and undo shield ground wire from ground stud. Remove sealant from around base of RSM and on mounting screws. Remove four (4) 8-32 non-ferrous mounting screws from RSM and remove RSM from aircraft taking care to guide 24 inch "pigtail" connector out through ½ inch hole in aircraft skin.

RSM Replacement

Verify power is off. Replace the O-ring on the RSM. Contact Aspen Avionics for replacement O-ring (256-00001-001). Verify RSM shim is installed between aircraft skin and RSM if required. Feed circular connector down through ½ inch hole in aircraft skin and mount RSM (vent hole faces aft) with four (4) 8-32 non-ferrous screws. Tighten to 12-15 in-lbs. It is critical that the screws be non-ferrous to prevent the introduction of compass errors. Connect the circular electrical connector and cable tie harness to prevent chaffing and interference. Connect shield ground wire to ground stud. For RSM locations that are external or in a wet environment seal around base and on top of four mounting screws of the RSM using one of the following non-corrosive sealants:

Non-pressure vessel mounting Dow Corning 738, MIL-A-46146 or equiv.

Pressure vessel mounting Pro-Seal PS 870B-1/2, MIL-PRF-81733D, or equiv.

Verify proper bonding per Section 10.1.2, and perform RSM Calibration per Section 10.5 of the EFD1000 and EFD500 SW v2.X Installation Manual, 900-00003-001 Rev BY or later. Also check OAT operation per Section 10.6.4 and check RSM GPS operation per Section 10.6.6. For the E5 verify bonding per Section 10.2 and perform RSM Calibration per Section 10.5 of the EFD1000 E5 Dual Electronic Flight Instrument (EFI) Install Manual 900-00041-001 Rev () or later.

CM Removal

Verify power is off. Cut the two (2) cable ties affixing the CM to the PFD wiring harness. Unplug the Molex connector by pressing down on the locking tab and gently pulling the connector from the module.

CM Replacement

Verify power is off. Plug the Molex connector into the module until it clicks. Cable tie the module to the PFD wiring harness.

Perform the Installation Menu Unit Configuration per section 10.4.5 of the EFD1000 Installation Manual, 900-00003-001 Rev BY or later (or 900-00041-001 Rev () or later, for E5).

Perform RSM Calibration per Section 10.5 of the EFD1000 and EFD500 SW v2.X Installation Manual, 900-00003-001 Rev BY or later (or 900-00041-001 Rev () or later, for E5).

To display the angle of attack (AOA) indicator (if enabled), perform the AOA Calibration Instructions in the EFD1000 and EFD500 SW v2.X Installation Manual, 900-00003-001 Rev BY or later.

EA100 Removal

Verify power is off. Remove the EA100 by unscrewing the jackscrews of both D-sub connectors. Gently remove the connectors by pulling straight out. Remove the six (6) 6-32 mounting screws securing the EA100 to the aircraft and remove unit from aircraft.

EA100 Replacement

Verify power is off. Install EA100 in mounting location and install six (6) 8-32 mounting screws through holes in EA100 mounting tabs. Tighten to 12 in-lbs. Install both D-sub connectors, securing each with the two jackscrews per connector.

Verify EA100 bonding per the Mechanical Installation section and perform post installation tests in the EFD1000 and EFD500 SW v2.X Installation Manual 900-00003-001 Rev BY or later (or 900-00041-001 Rev () or later, for E5), Appendix E.

If the EA100 being installed is a replacement then configure it using the EA100 Alignment Tool and set the values to those recorded on the configuration table in the permanent aircraft records.

EBB58 Removal

Verify power is off. Unscrew two jackscrews that secure the D-sub connector to the battery and then unplug the connector. Spread battery tray hold down clips outward to release battery and slide battery out of tray.

EBB58 Replacement

Verify power is off. Slide battery into tray until hold down clips lock into place. Install D-sub connector and secure with both jackscrews.

NOTE: If the spring clip(s) are sprung so the pins do not fully seat, the mounting bracket must be replaced.

Turn on the EFD1000 MFD or EBD and switch unit to battery. Verify charge of 80% or greater. If battery is below 80% then charge battery to above 80% by switching EFD back to aircraft power. EBB58 battery will recharge as long as EFD is powered up on aircraft power.

EBB58 Tray Removal

Verify power is off. Remove the battery. Remove the four screws securing the tray to the airframe.

EBB58 Tray Replacement

Replace the four screws securing the tray to the airframe. Tighten to 12 in-lbs. Verify proper bonding per Section 10.1.2 of the EFD1000 Installation Manual, 900-00003-001 Rev BY or later.

APS4A Removal

Verify power is off. Remove the APS4A by unscrewing the jackscrews of the D-sub connector. Gently remove the connector by pulling straight out. Remove the four mounting screws securing the APS4A to the aircraft and remove unit from aircraft.

APS4A Replacement

Verify power is off. Install APS4A in its mounting location and install four 6-32 mounting screws through holes in APS4A mounting tabs. Tighten to 12 in-lbs. Install the D-sub connector, securing with two jackscrews per connector.

Verify APS4A bonding per the Mechanical Installation section and perform post installation tests in accordance with Appendix G - EFD1000 Installation Manual, 900-00003-001 Rev BY or later.

CG100 Removal

Verify power is off. Remove the CG100 by unscrewing the jackscrews of the D-sub connectors. Gently remove the connectors by pulling straight out. Remove the six mounting screws securing the CG100 to the aircraft and remove unit from aircraft.

CG100 Replacement

Verify power is off. Install CG100 in its mounting location and install six 6-32 mounting screws through holes in CG100 mounting tabs. Tighten to 12 in-lbs. Install the D-sub connectors, securing with two jackscrews per connector. Note - it may be necessary to remove the antenna from the old CG100 and install it on to the SMA connector of the replacement CG100.

Verify CG100 bonding per the Mechanical Installation section and perform post installation tests in accordance with Appendix H - EFD1000 Installation Manual, 900-00003-001 Rev BY or later.

NOTE: Appendix H of document 900-00008-001 directs the user to another supporting document (900-000023-001, see "CG100 Installation, and "System Checkout") information for the CG100. This is because the primary document for the STC is document 900-00003-001, and information regarding support documentation will be in this document.

15 Wiring and Component Location Data

INSTRUCTIONS:

NOTE: The wire routing information placed here by the installer must be detailed enough to enable maintenance personnel to troubleshoot, repair, and service the electrical system. These diagrams must also include a method of determining connector type (if other than the connectors supplied by Aspen Avionics in the Installation Kits), wire type, and wire size. The system wiring diagrams are descriptive data of the systems used on the aircraft, and are part of the ICA.

- a) Draw in the locations of the EFD1000 system, including the EFD(s) (PFD, EBD, E5, MFD), RSM, optional ACU/ACU2, EBB58, EA100, CG100 and autopilot locations (Figures 1 and 2).
- b) Draw in the circuit breaker and switch locations on instrument panel (Figure 3).
- c) Draw in the EFD to RSM cable routing, including wire type and wire size.
- d) Draw in the ACU to EFD and ACU to autopilot cable routing, including wire type and wire size.
- e) Draw in the optional EA100 to EFD and EA100 to autopilot cable routing, including wire type and wire size.
- f) Draw in the optional CG100 to MFD cable routing.
- g) Draw in the optional CG100 USB port locations.
- h) Show the location of access panels for inspection and servicing the EFD1000 system, including diagrams of the access plates and any information necessary to gain access when access plates are not provided.

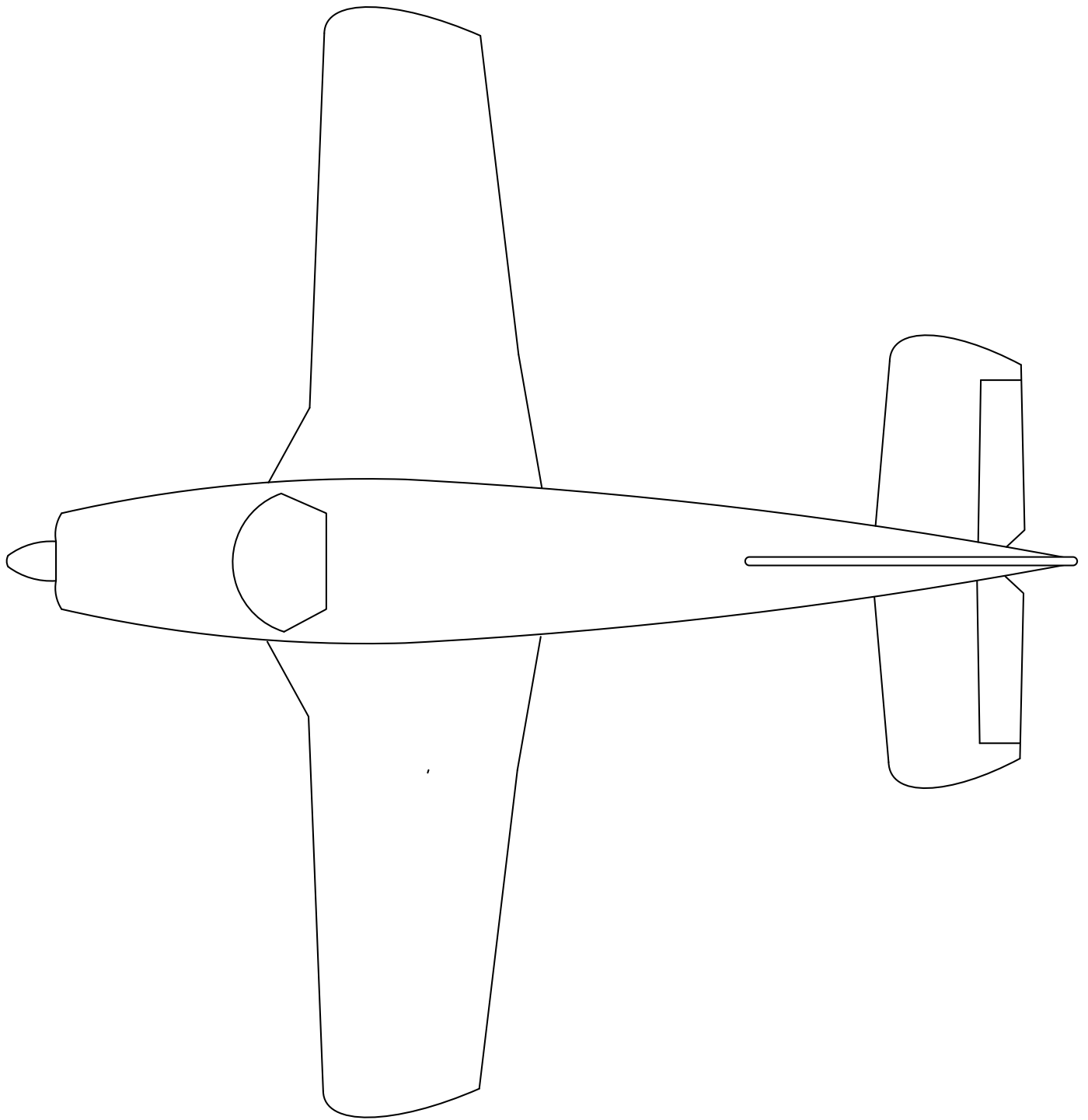

Figure 1 - EFD1000 Components and cable routing (top view)

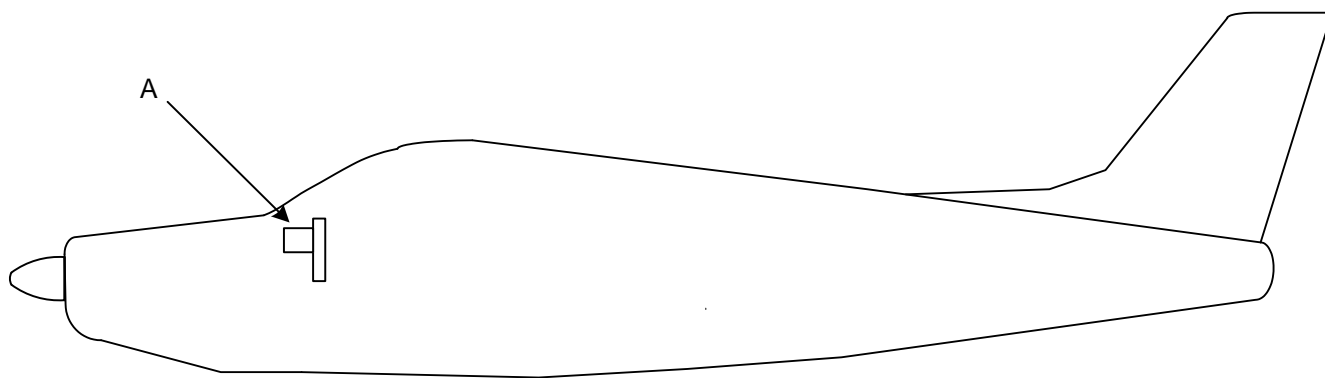

Figure 2 - EFD1000 Components and cable routing (side view)

LRU Definitions

- | | |
|---------------------------------------|--|
| A. EFD (CM is wired within 6" of EFD) | G. EBB58 - optional equipment |
| B. RSM (PFD, EBD, or E5) | H. Autopilot computer location -optional equipment |
| C. ACU/2 #1 - optional equipment | J. EWR50 location - optional equipment |
| D. ACU/2 #2 - optional equipment | K. EA100 location - optional equipment |
| E. MFD#1 and MFD#2 -optional | L. APS4A location - optional equipment |
| F. RSM (MFD) - optional | M. CG100 - optional equipment |

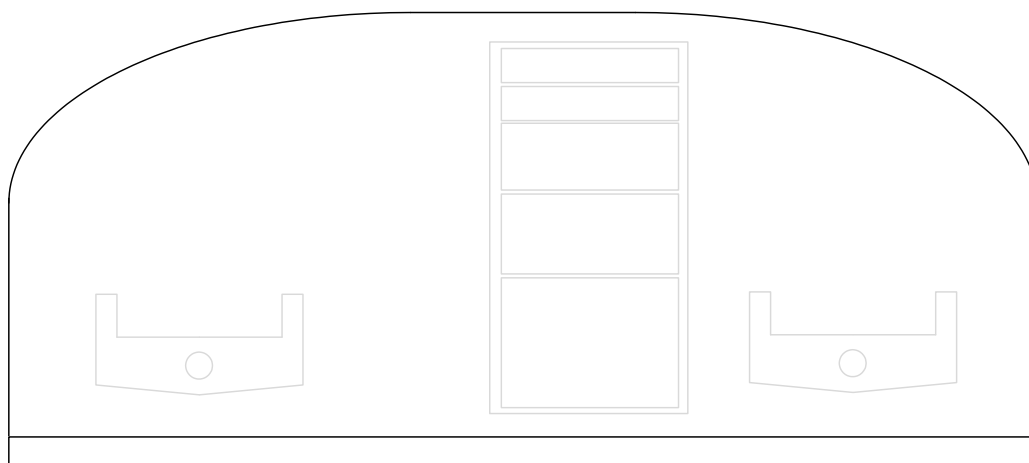

Figure 3 - Circuit Breaker and Switch Locations

Circuit Breaker and Switch Definitions

- a) PFD/MFD/EBD/E5 circuit breakers
- b) PFD/MFD/EBD/E5 switch(s)
- c) ACU circuit breaker(s) - optional
- d) A/P AHRS circuit breaker -w/opt. EA100
- e) EBB58 Emergency Disconnect Switch
- f) A/P AHRS FAIL light - w/ opt. EA100
- g) PRESEL/(ARMED) switch - optional
- h) A/P Source switch - optional
- i) GTWY circuit breaker - optional
- j) ASPEN GTWY switch - optional

INSERT WIRING DIAGRAMS AFTER THIS PAGE

(The drawings must include detailed information on the interface of the EFD1000 system suitable for system troubleshooting)

INSERT THE FOLLOWING AFTER THIS PAGE

All inserts are from EFD1000 and EFD500 SW v2.X Installation Manual, 900-00003-001 Rev BY or later. For the EFD1000 E5 Dual EFI, the inserts are from the EFD1000 E5 Flight Display Installation Manual, 900-00041-001 Rev () or later. The sections and paragraph numbers in brackets [] are the locations in the 900-00041-001 document.

COMPLETED – CONFIGURATION PAGES – Section 10.4.6 & 10.4.7 [10.4.6]

COMPLETED – PRE-MODIFICATION CHECKLIST – TABLE 5-1 & 5-2 & 5-3 [Table 5-1]

COMPLETED – OPERATOR CONFIGURATION CHECKLIST FROM APPENDIX C [Installed Equipment Configuration Matrix from Appendix C]

COMPLETED – EFD1000/500 INSTALLATION FINAL CHECKSHEET FROM APPENDIX B [Appendix B]

COMPLETED – EA100 FLIGHT TEST and CONFIGURATION TABLE FROM APPENDIX E [Appendix E]